



Installation Instructions

Trektop PRO Wiper Motor Kit

Vehicle Application:
Bestop Trektop PRO
 2007-current
 Part Number 54858

Installation Tips

Before you begin installing your new Trektop PRO Wiper Motor Kit, please read all the instructions thoroughly.

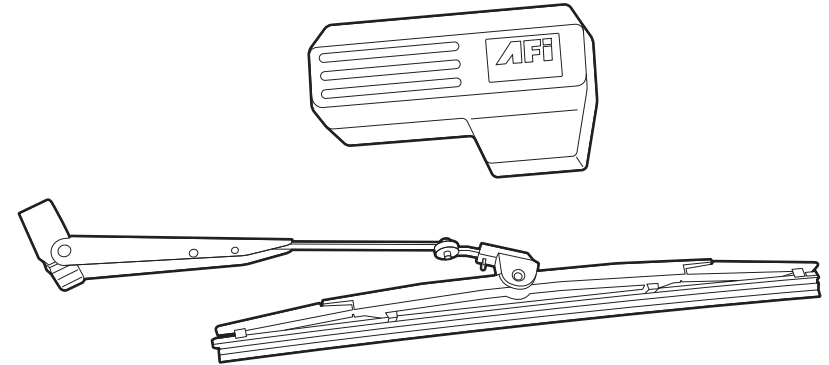

CAUTION Safety glasses should be worn at all times when installing this product.

Tools				Installation Time	Support
				1 Hour	<p>We're here to help! Go to www.Bestop.com and click "Contact Us"</p>  <p>See a video showing installation of this top at www.bestop.com/video</p>
#2 Phillips Screwdriver	2.5mm Allen Wrench	3/8" Wrench			
				Skill Level 2 - Moderately Easy	
3/4" Deep-Well Socket	1/2" & 7/16" Sockets	Safety Glasses	Torque Wrench		

WARNING This product is designed primarily to enhance the appearance of the vehicle and to shield the occupants from ordinary weather conditions. Do not rely in any way on the components of this product to contain occupants within the vehicle, or to protect against injury or death in the event of an accident. This product will not protect the occupants from falling objects. Never operate the vehicle in excess of manufacturer's specifications.

WEAR SEAT BELTS AT ALL TIMES

Read and follow, precisely, all installation instructions provided when installing this product. Failure to do so may result in a poor fit and could place occupants of the vehicle in a potentially dangerous situation.



Installation Instructions Trektop PRO Wiper Motor Kit

Vehicle Application:
Bestop Trektop PRO
2007-current
Part Number 54858

Sugerencias de Instalación

Antes de empezar a instalar esta unidad, lea atentamente todas las instrucciones.



ADVERTENCIA

Este producto se diseñó principalmente para mejorar la apariencia del vehículo y proteger a los ocupantes de las condiciones climáticas comunes. De ninguna manera piense que los componentes de este producto pueden servir como medio de contención para los ocupantes del vehículo o que pueden protegerlos contra lesiones o la muerte en caso de accidente. Este producto no protegerá a los ocupantes contra caídas de objetos. Nunca conduzca este vehículo fuera de las especificaciones del fabricante.

USE LOS CINTURONES DE SEGURIDAD EN TODO MOMENTO

Lea y siga con precisión todas las instrucciones de instalación que se proporcionan para instalar este producto. Si no lo hace, podría producirse un mal ajuste que colocaría a los ocupantes del vehículo en una situación potencialmente peligrosa.



PRECAUCIÓN

Debe usar gafas protectoras en todo momento durante la instalación de este producto.

Conseils pour l'installation

Lire toutes les instructions au complet avant de commencer l'installation de cet assemblage.



AVERTISSEMENT

Ce produit est conçu principalement pour améliorer l'apparence du véhicule et pour protéger les occupants des conditions météorologiques usuelles. Ne jamais se fier aux composants de ce produit pour se protéger de blessures ou de la mort en cas d'accident. Ce produit ne protégera pas les occupants des chutes d'objets. Ne jamais utiliser le véhicule au-delà des caractéristiques techniques indiquées par le fabricant.

PORTER UNE CEINTURE DE SÉCURITÉ EN TOUT TEMPS

Lire et suivre, très fidèlement, toutes les instructions d'installation fournies lors de l'installation de ce produit. Ne pas suivre cette consigne peut causer une installation inadéquate et mettre les occupants du véhicule dans une situation potentiellement dangereuse.



MISE EN GARDE

Des lunettes de sécurité doivent être portées en tout temps lors de l'installation de ce produit.





Installation Instructions Trektop PRO Wiper Motor Kit

Vehicle Application:
Bestop Trektop PRO
2007-current
Part Number 54858

Parts List

- Required parts for each installation section - Page number in Installation Guide

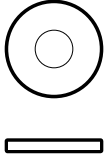
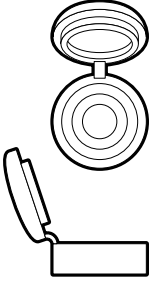
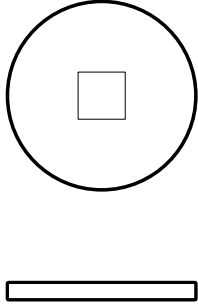
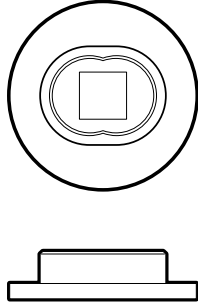
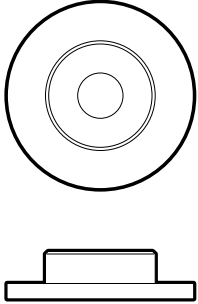
All Sections	Fasteners and Hardware					Multiple Pages
						
#10-32 x 1.25 Screw Qty. 1 Part # 316.93	#10-32 Nylock Nut Qty. 1 Part # 316.94	#10 Washer Qty. 1 Part # 514.63	Screw Cap Qty. 1 Part # 514.65	Inner Isolator Qty. 2 Part # 513.03	Outer Isolator Qty. 1 Part # 510.03	Bushing Qty. 1 Part # 514.01

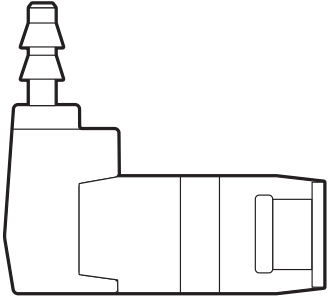
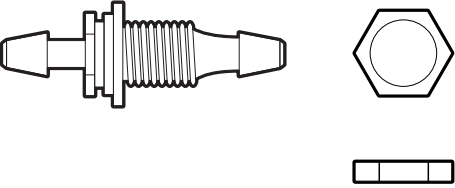
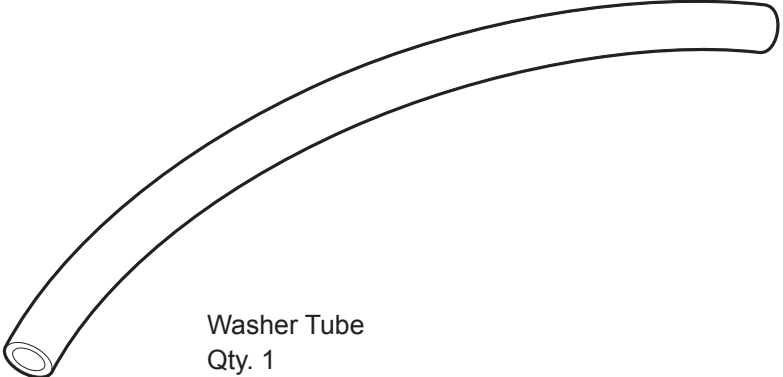
Sections 3 & 5	Washer - Wiper Hardware	Page 7,8 & 12 of Guide
		
Wiper Nozzle Qty. 1 Part # 514.66	Washer Coupler & Nut Qty. 1 Part # 514.67	Washer Tube Qty. 1 Part # 512.64





Installation Instructions Trektop PRO Wiper Motor Kit

Vehicle Application:
Bestop Trektop PRO
2007-current
Part Number 54858

Parts List

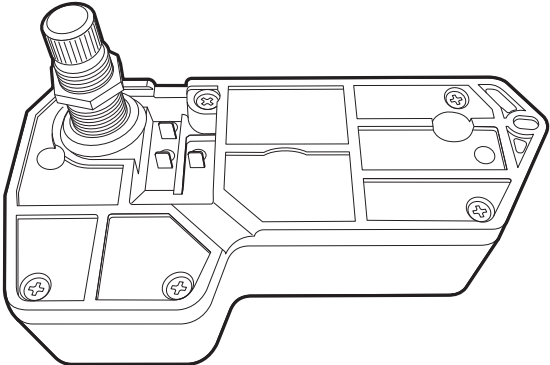
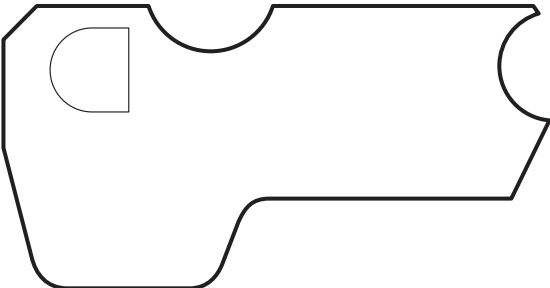
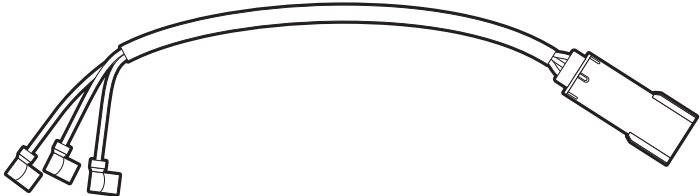
- Required parts for each installation section - Page number in Installation Guide

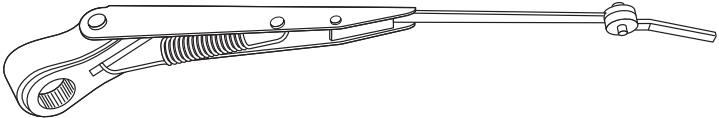
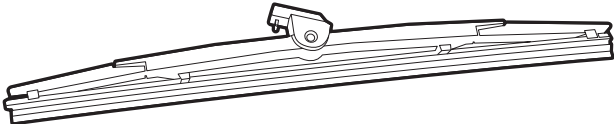
Sections 1 & 2	Wiper Motor, Wiper Motor Gasket	Pages 4 & 5 of Guide
 <p>Wiper Motor Qty. 1 Part # 512.61</p>	 <p>Wiper Motor Gasket Qty. 1 Part # 514.61</p>	
Sections 1 & 4	Wiring Harness, Wiper Arm & Wiper Blade	Pages 4, & 9 - 11 of Guide
  <p>Wiper Wiring Harness Qty. 1 Part # 512.65</p>	 <p>Wiper Arm Qty. 1 Part # 512.62</p>  <p>Wiper Blade Qty. 1 Part # 512.63</p>	

Step 1 512.61

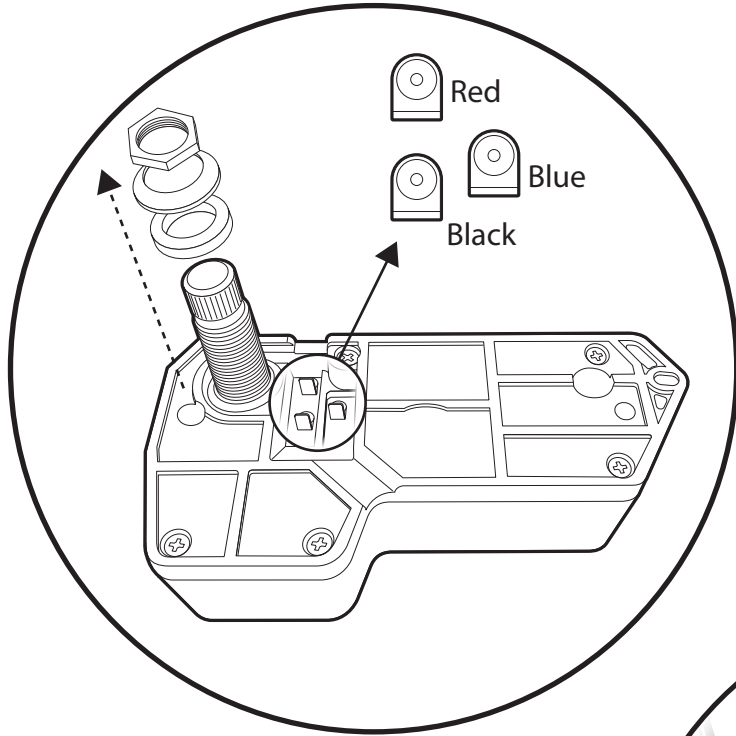

Hardware

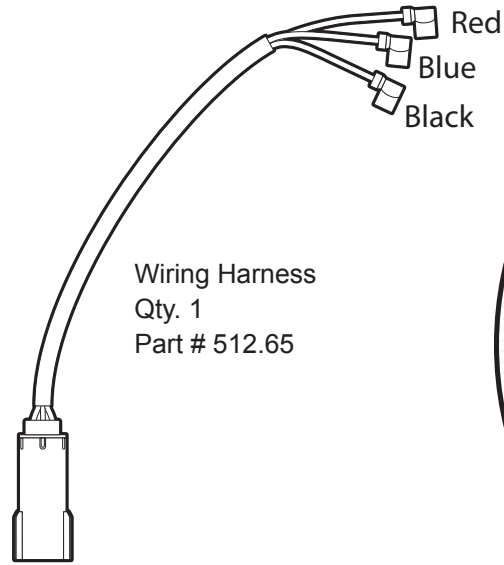

Step 2 512.65

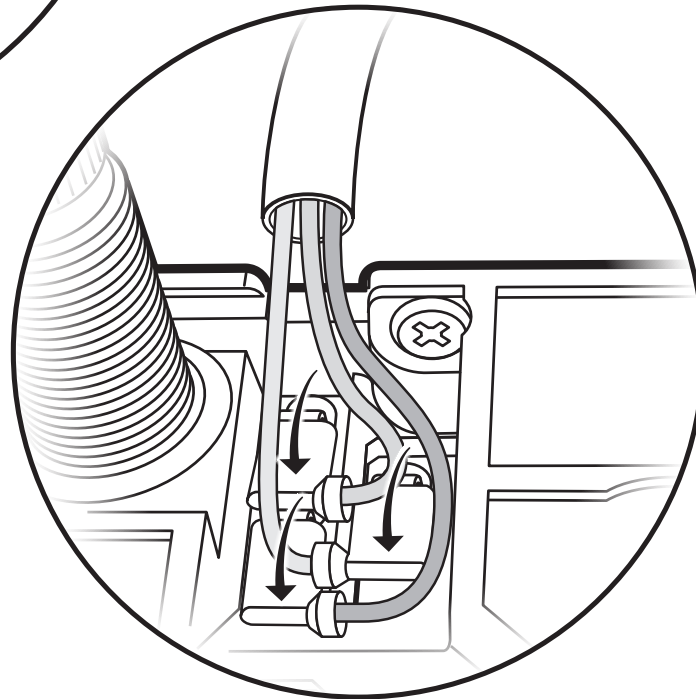
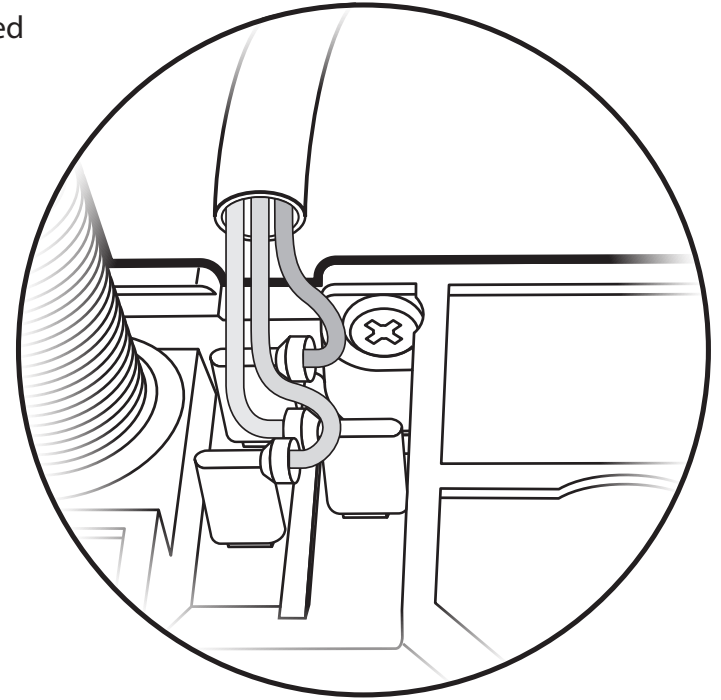

Step 1 514.66

Hardware

Step 2

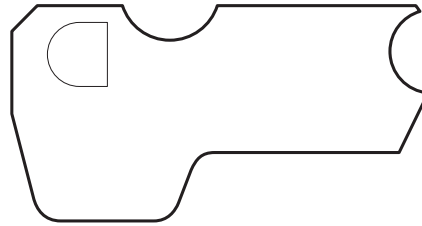
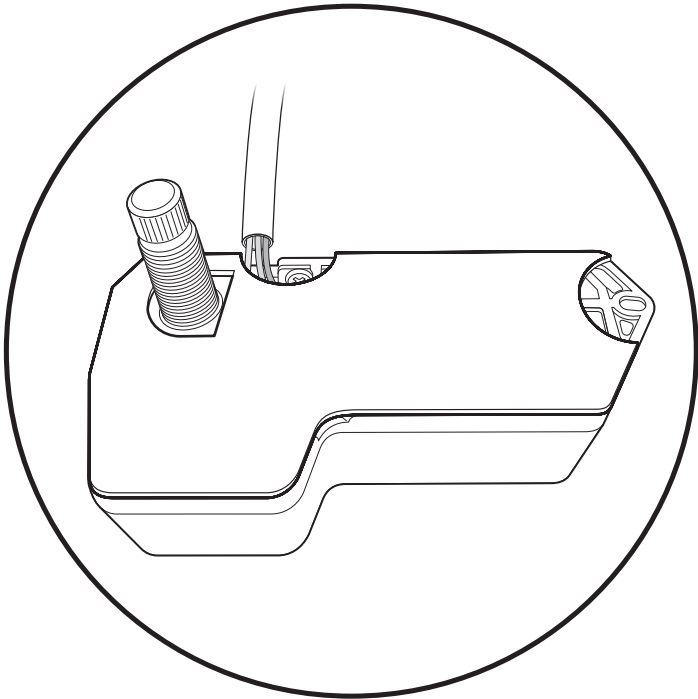

Wiper Motor Gasket
Qty. 1
Part # 514.61

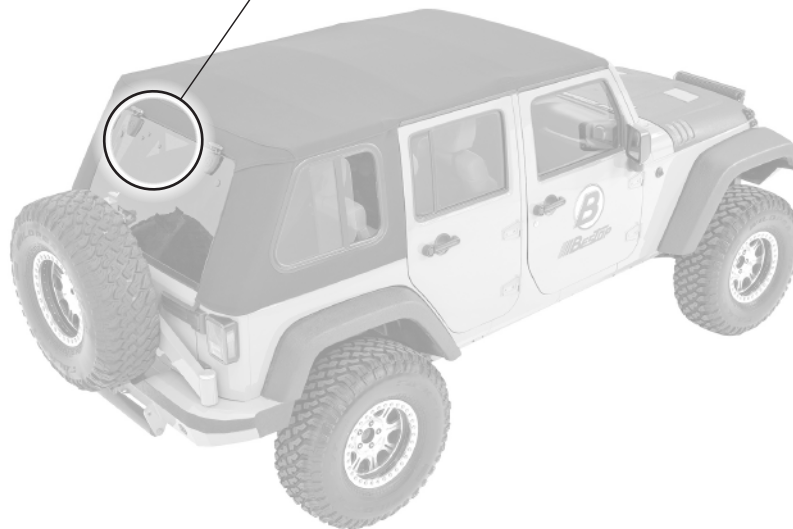
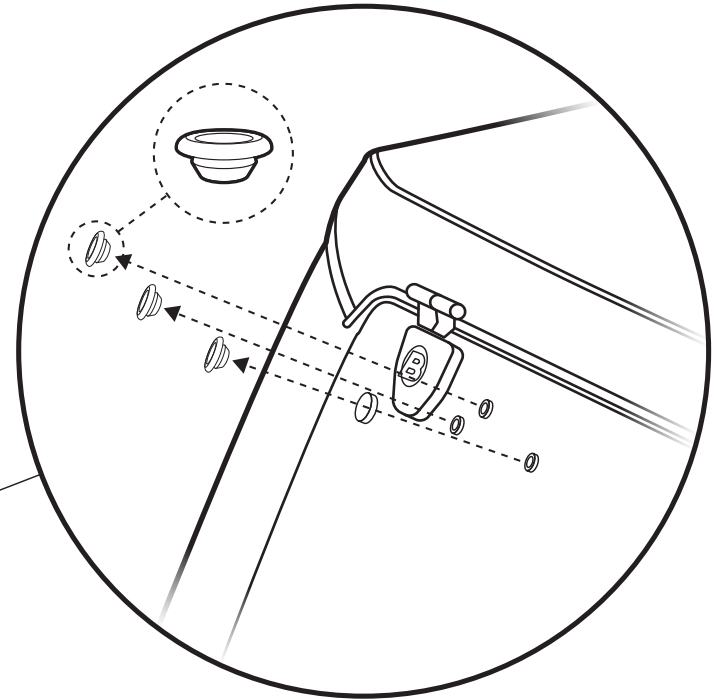

Step 1 512.61

Hardware

Step 2

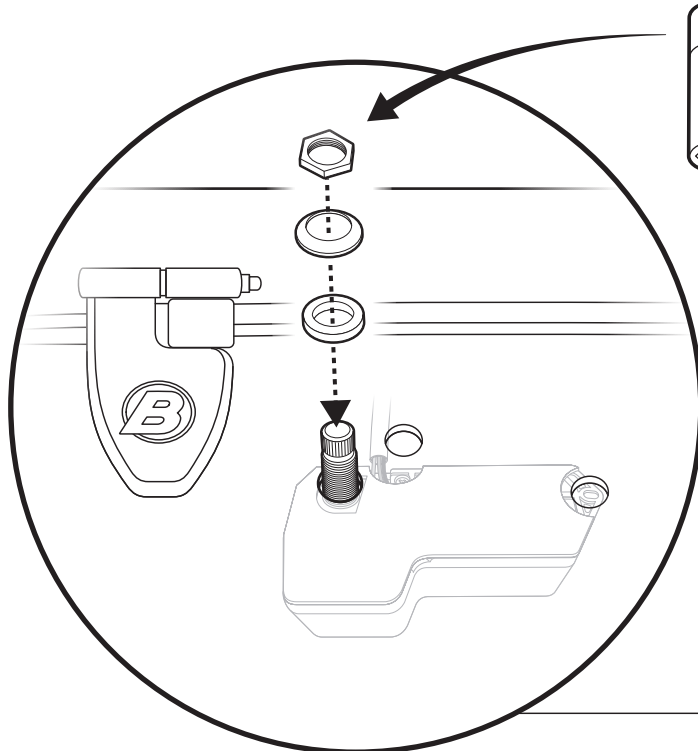

3/4" Deep-Well
Socket



#10-32 x 1.25
Screw
Qty. 1
Part # 316.93

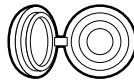

Screw Cap
Qty. 1
Part # 514.65

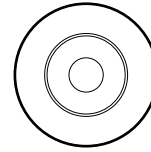

Bushing
Qty. 1
Part # 514.01

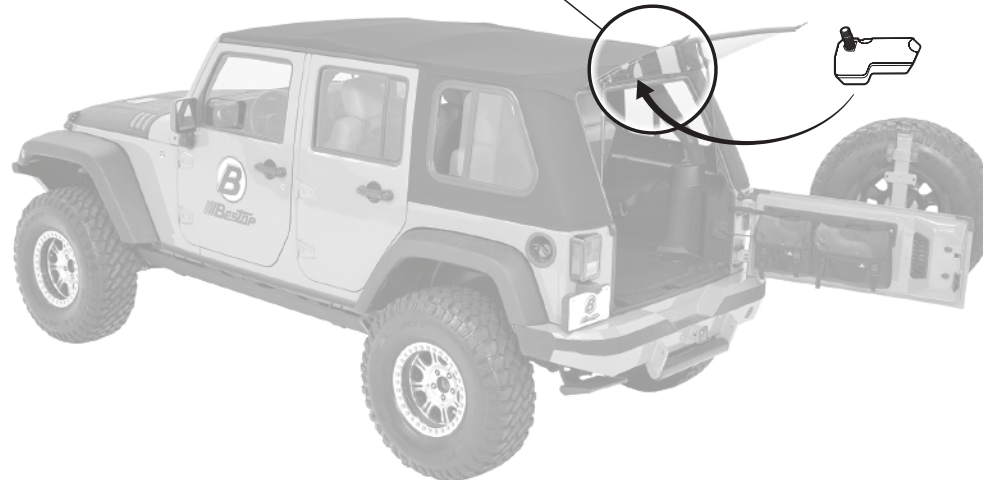
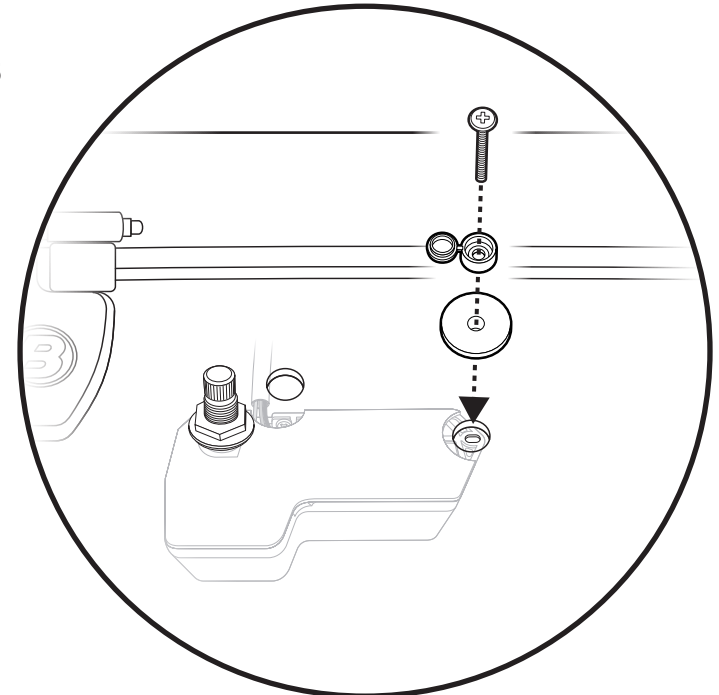

Step 3

#2 Phillips Screwdriver
3/8" Wrench

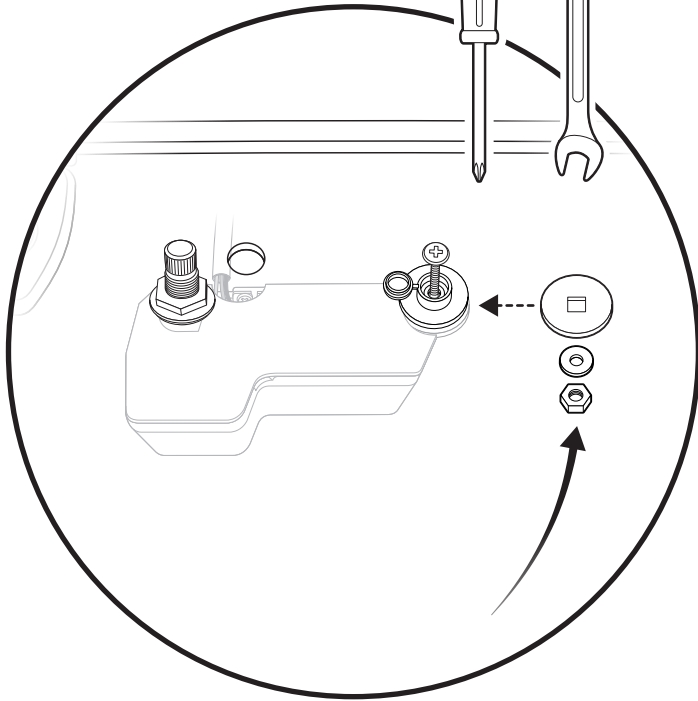

Hardware

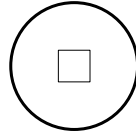

Inner Isolator
Qty. 2
Part # 513.03

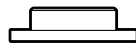
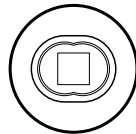

Outer Isolator
Qty. 1
Part # 510.03



Washer Coupler
and Nut
Qty. 1
Part # 514.67



#10-32
Nylock Nut
Qty. 1
Part # 316.94



#10 Washer
Qty. 1
Part # 514.63

Step 4

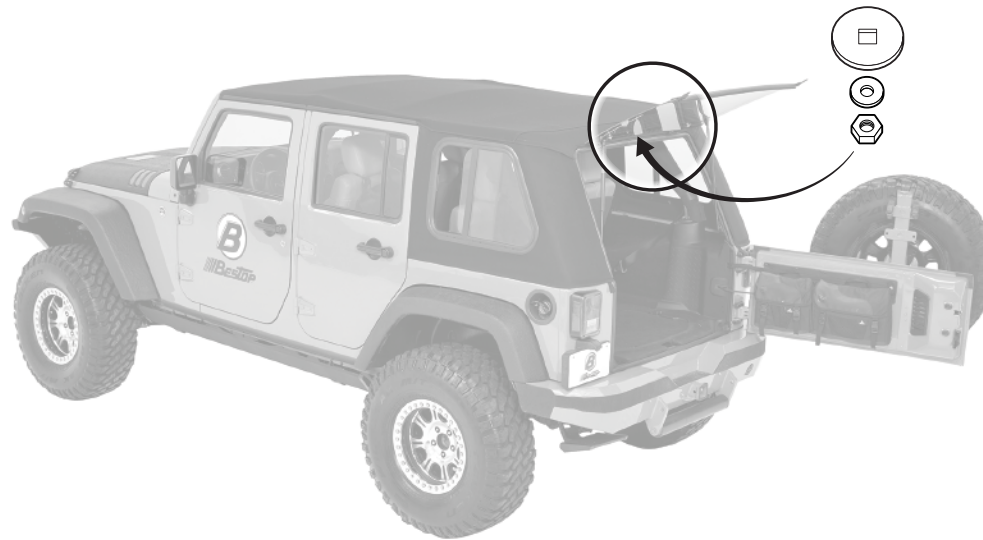
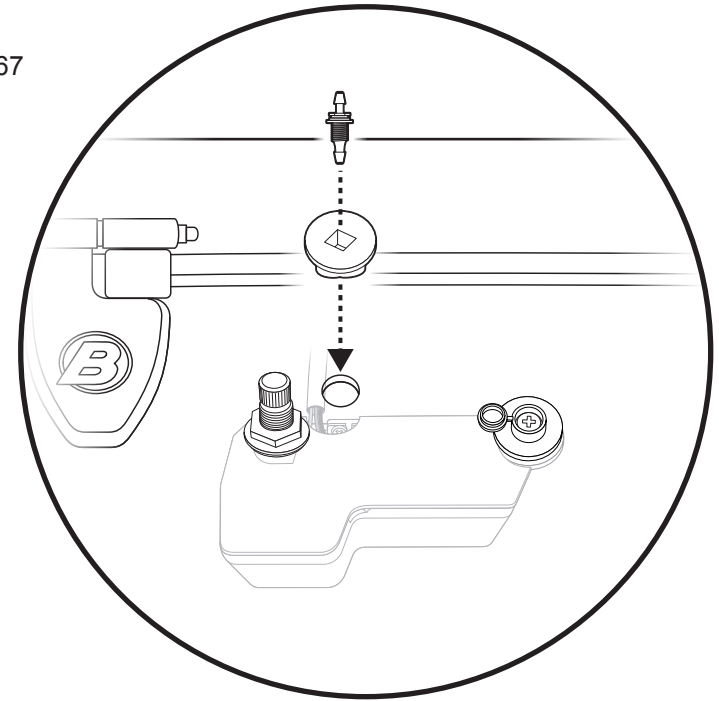

Step 5

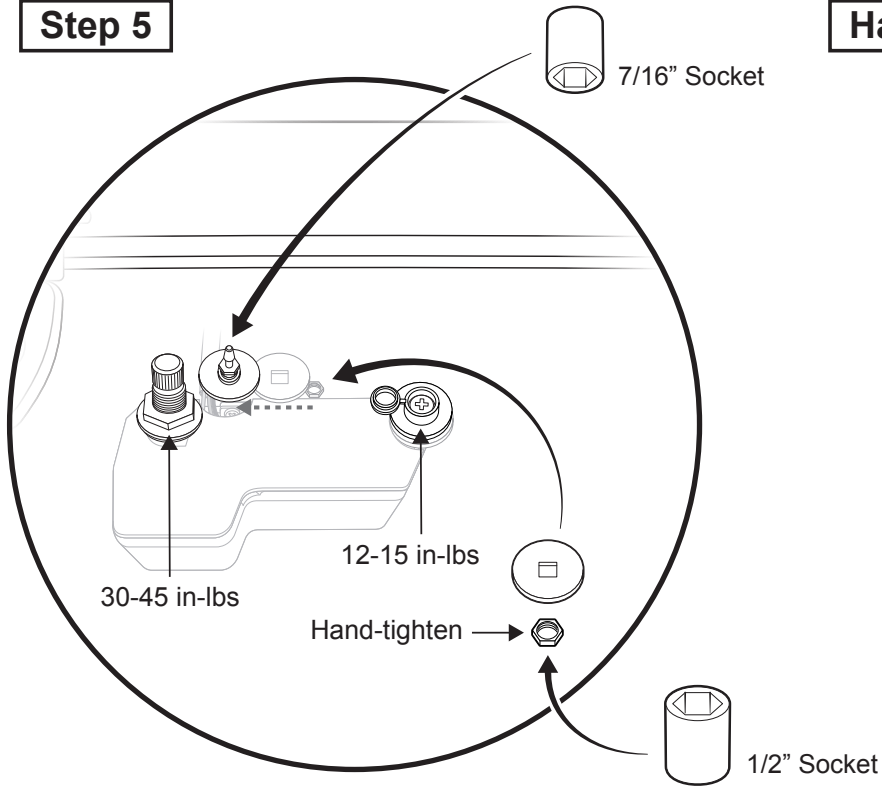

Hardware

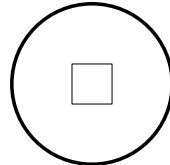
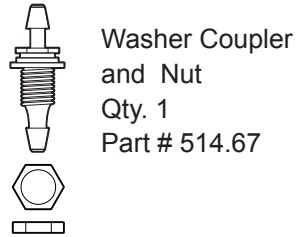

Step 6

SLOWLY tighten these parts to the following specifications using the torque wrench:

- #10 screw and #10 nut: 12-15 in-lbs
- Wiper output shaft nut: 30-45 in-lbs

Hand-tighten the Washer Coupler
- Do Not Overtighten!

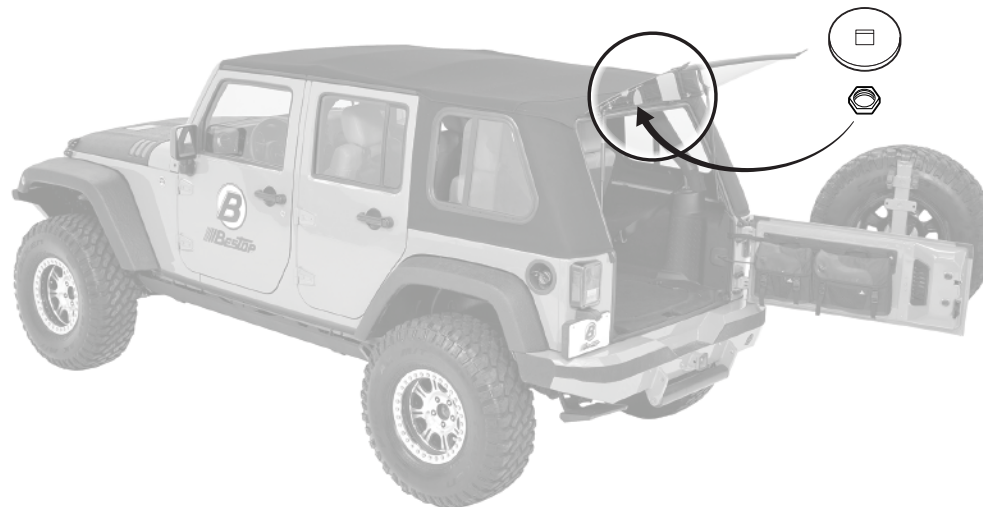

Step 1 512.62 512.63

Hardware

Step 2

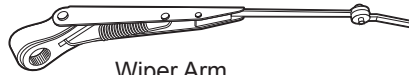
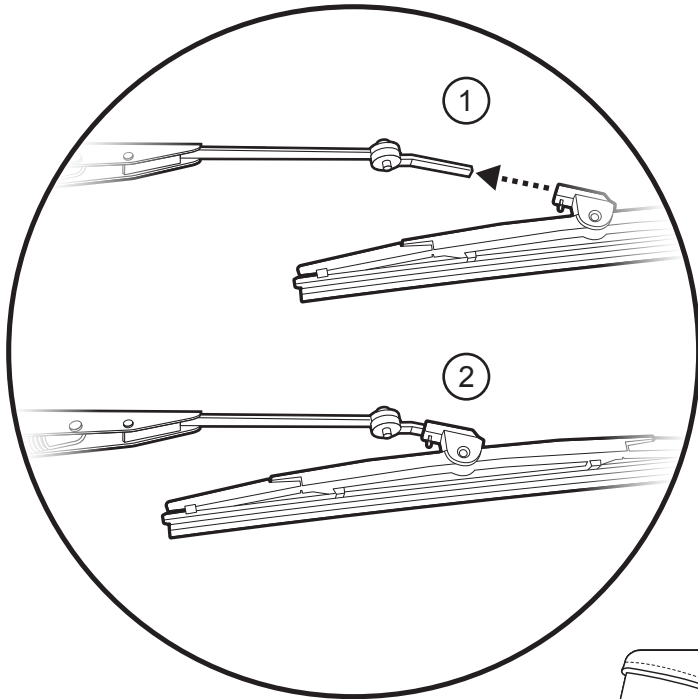

Wiper Arm
Qty. 1
Part # 512.62

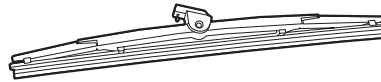

Wiper Blade
Qty. 1
Part # 512.63

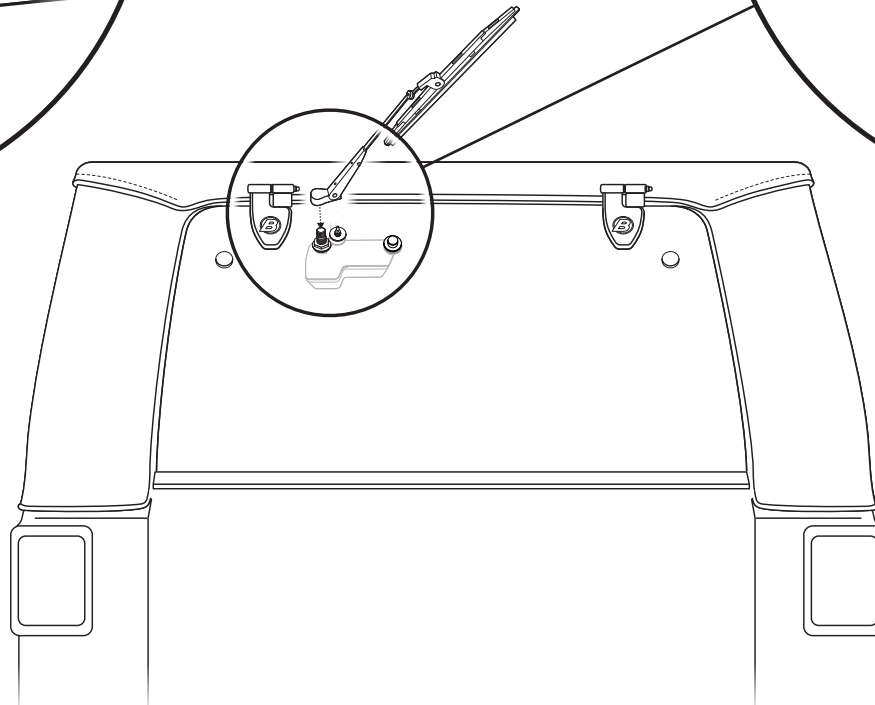
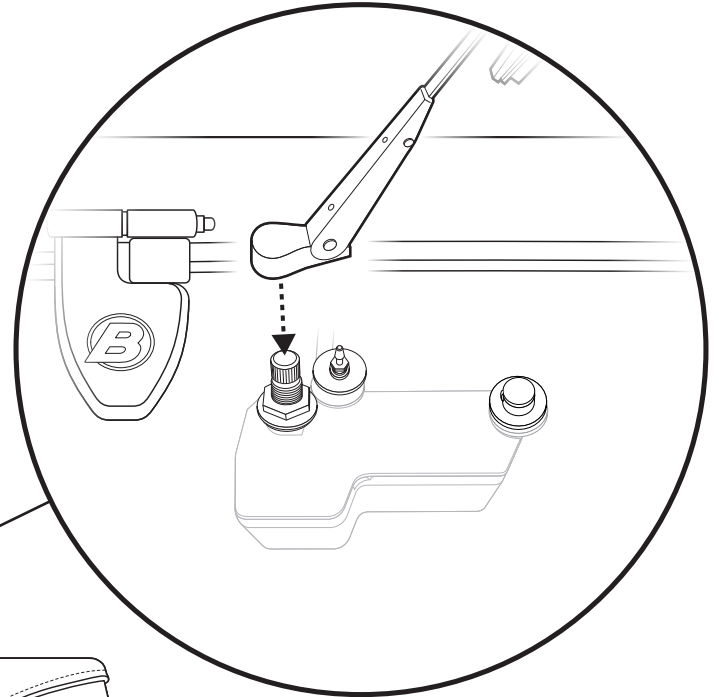

Step 3

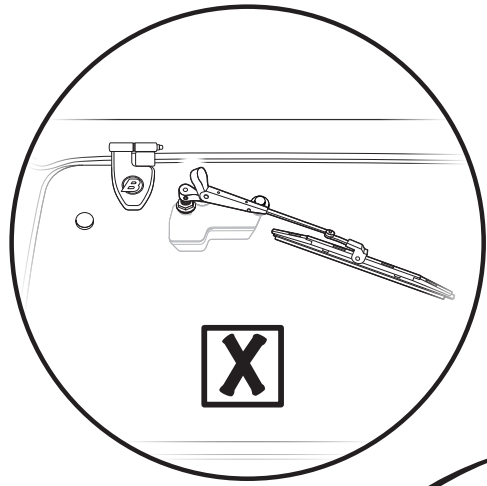
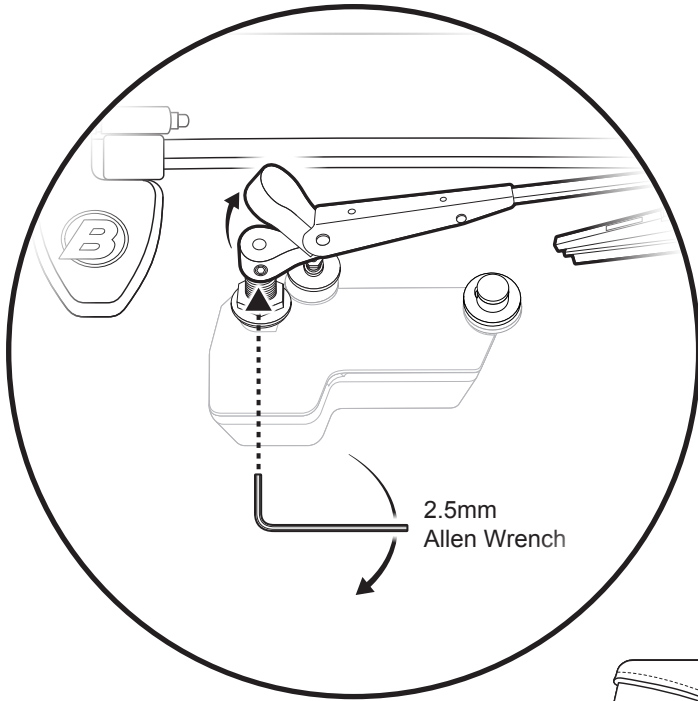

Step 4

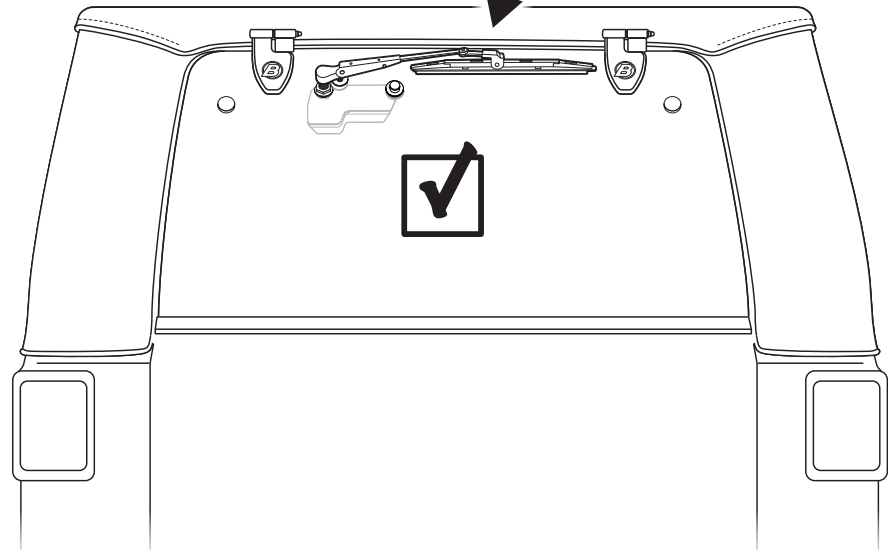
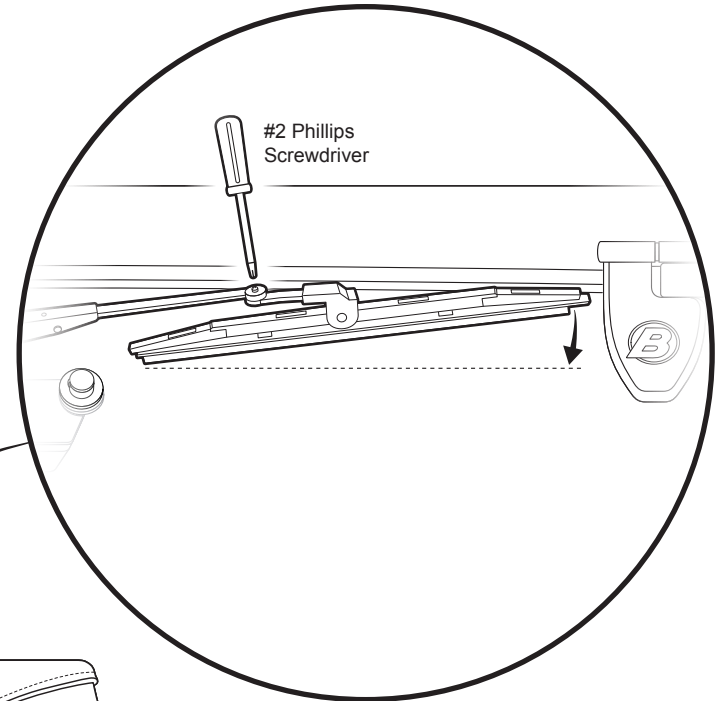

Step 5

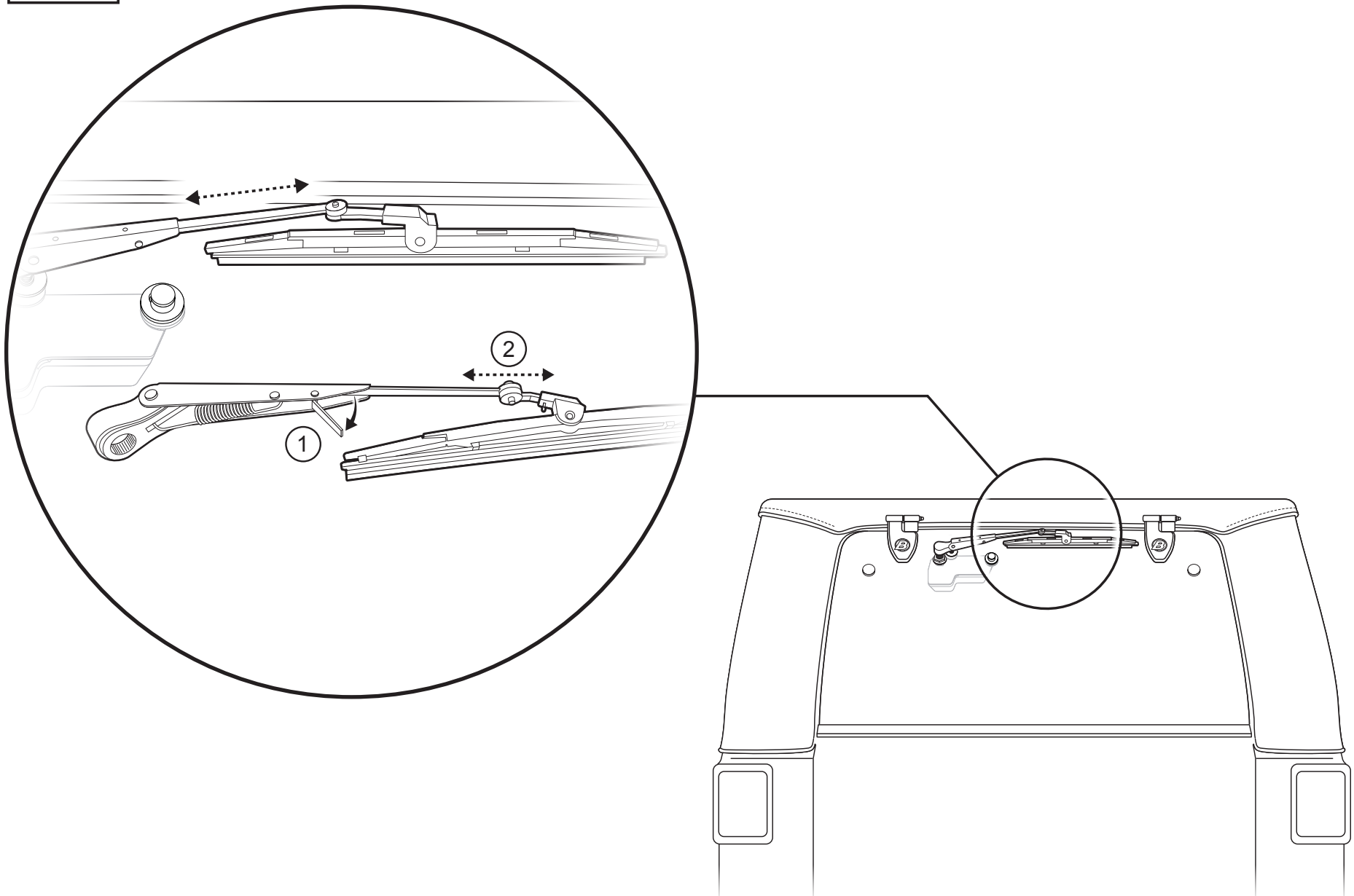

Step 1

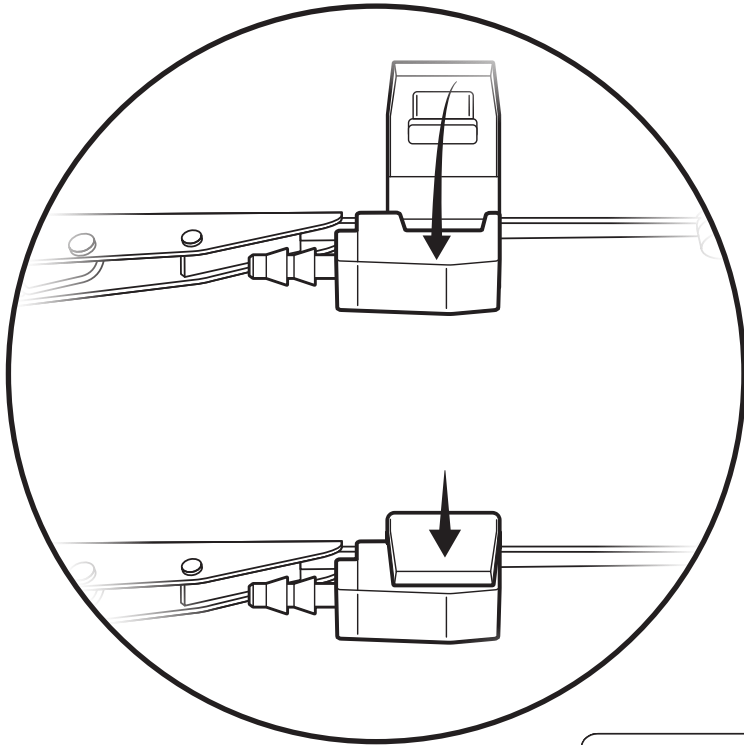

Hardware

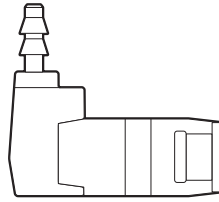

Wiper Nozzle
Qty. 1
Part # 514.66

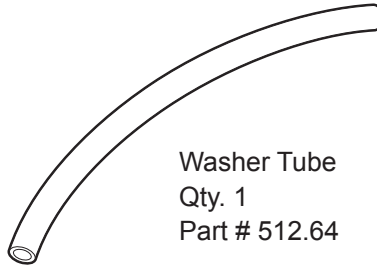

Washer Tube
Qty. 1
Part # 512.64

Step 2

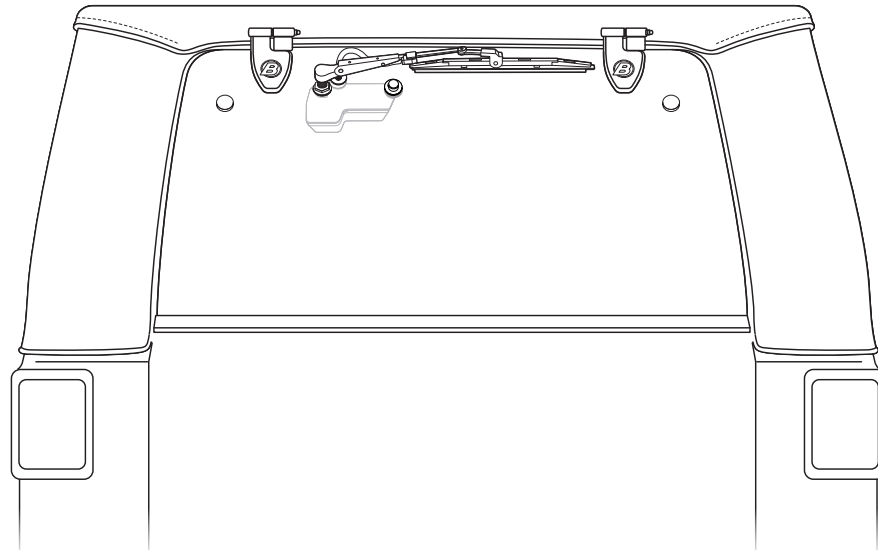
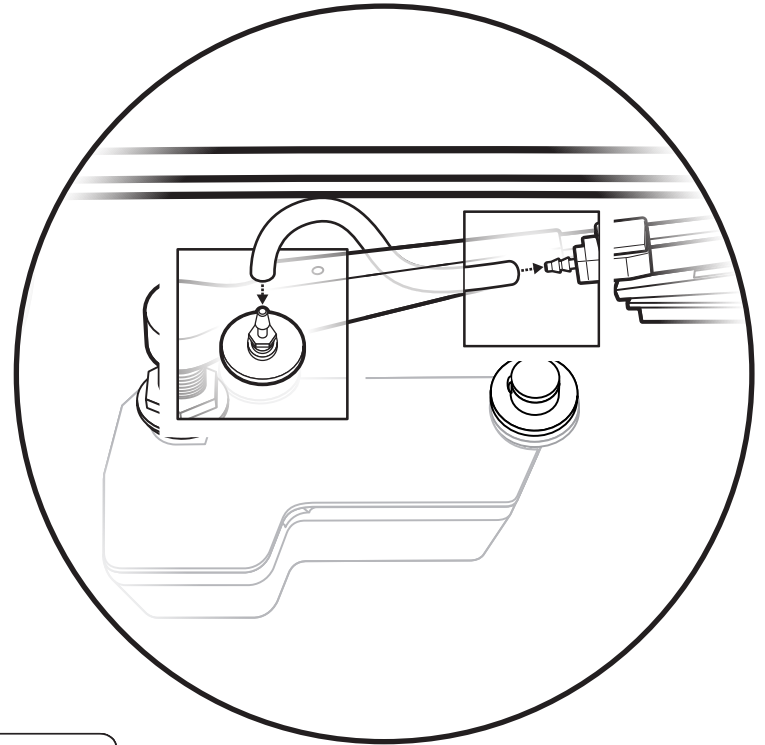

Step 1

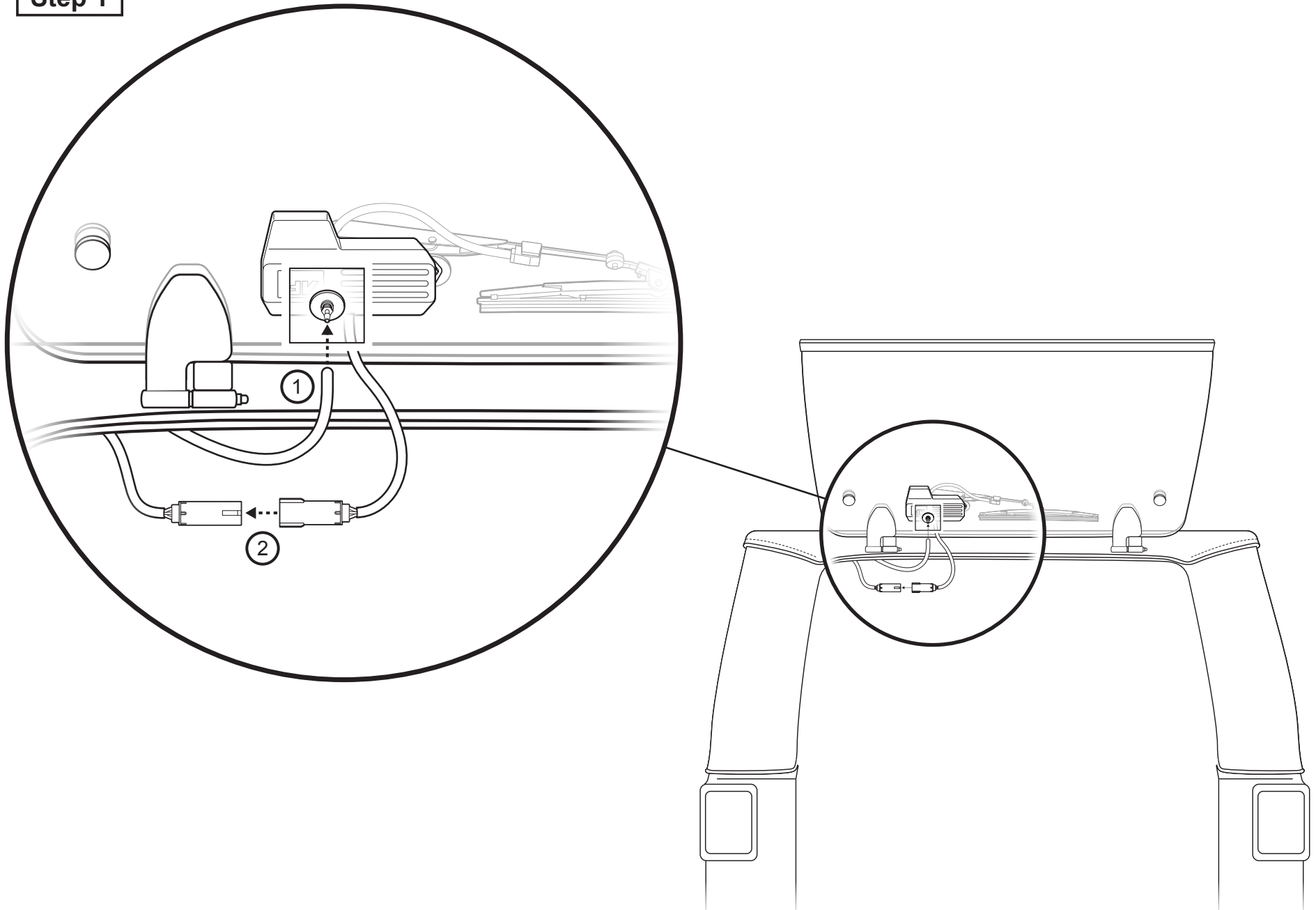



Installation Instructions Trektop PRO Wiper Motor Kit

Vehicle Application:
Bestop Trektop PRO
2007-current
Part Number 54858

Care and Maintenance of your Bestop Product

Your Bestop product is made of the finest materials available. To keep it looking new and for the maximum possible life, it will need periodic cleaning and maintenance.

Fabric: The fabric should be washed often using soap, warm water and a soft bristle brush. Rinse with clear water to remove all traces of soap. Bestop recommends using **Bestop Cleaner** (part no. 11201-00) and **Bestop Twill Protectant** (part no. 11207-00) which are specially formulated to provide a total cleaning and protection system

Windows: Keep windows clean to avoid scratching. DO NOT use a brush on the windows! Wash with a water-soaked cloth or sponge and a mild dishwashing detergent. Bestop recommends Bestop Vinyl Window Cleaner (part no. 11203-00), which safely cleans and protects vinyl windows and helps prevent UV damage. NEVER WIPE THE WINDOWS WHEN THEY ARE DRY. Be careful when cleaning snow or frost from the vinyl windows since they are easily scratched and may crack at low temperatures. DO NOT roll the sides or rear window in cold weather. The windows become stiff and will crack. Cracks caused by misuse in cold temperatures are not covered under warranty.

Zippers: Keeping zippers cleaned and lubricated with **Bestop's Zipper Cleaner** (part no. 11206-00) will help prevent damage and keep the zippers in smooth working condition. If a zipper opens behind the slider, the slider may have been spread apart. This problem can usually be repaired by using an ordinary pair of pliers to bring the sides back into parallel. Return slider to the end of the zipper in the normal Open position. Squeeze lightly at first and test the zipper. If the zipper continues to remain open squeeze more firmly with the pliers and try the zipper again. Repeat this procedure until the zipper operates correctly.

Water: Seeping through at the seams may be stopped by applying 3-M Scotchgard® on the inside of the seams. Rips in the fabric may be repaired with Bondex® iron on patches. Iron the patches to the Inside of the top, carefully following the Bondex® instructions.

Snaps: Keep snaps cleaned and lubricated with silicone to help prevent snaps from sticking to the studs. If a snap does become stuck to a stud, use a screwdriver and GENTLY pry apart to prevent permanent damage to the snap or the top fabric.

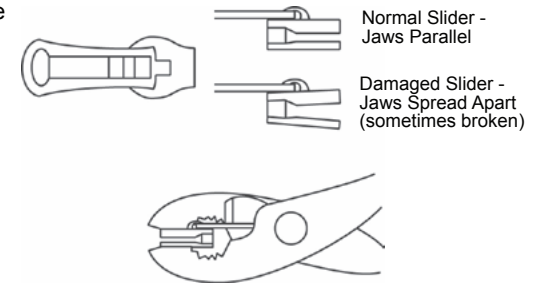



BESTOP WARRANTY SUMMARY

Updated July 2017



WHAT BESTOP WARRANTS

Subject to the terms and conditions of sale, including any terms and conditions set forth by Bestop, Inc. ("Bestop" or "us" or "we") in our then-current terms of sale on our website (collectively, the "Terms"), Bestop represents and warrants that: the covered products listed in the "Covered Products and Warranty Periods" section (a "Product") will substantially be free from defects in materials and workmanship for the specified warranty periods set forth in that section.

THE WARRANTY IS LIMITED AND CONDITIONAL

This warranty applies to the original purchaser of the Product only. The warranty is valid only as long as the original retail purchaser owns the vehicle upon which the Product is installed. The warranty expires should the Product be removed from the original vehicle or if the original vehicle is transferred to another owner. This warranty is not transferable or assignable. The warranty does not apply to Product bought from auction-style or price-bid websites.

THE LIMITED WARRANTY AND STATED REMEDIES ARE SOLE AND EXCLUSIVE AND IN LIEU OF ALL OTHER WARRANTIES AND REMEDIES, AND COMPANY EXPRESSLY DISCLAIMS ALL IMPLIED OR STATUTORY OR OTHER WARRANTIES, INCLUDING WITHOUT LIMITATIONS WARRANTIES OF MERCHANTABILITY, NON-INFRINGEMENT OR FITNESS FOR A PARTICULAR PURPOSE. IN NO EVENT WILL COMPANY BE LIABLE FOR ANY SPECIAL, INCIDENTAL, CONSEQUENTIAL, PUNITIVE, INDIRECT OR EXEMPLARY DAMAGES OF ANY KIND, INCLUDING LOST PROFITS OR REVENUE, HOWEVER CAUSED, WHETHER FOR BREACH OR REPUDIATION OF CONTRACT, TORT, BREACH OF WARRANTY, NEGLIGENCE, OR OTHERWISE, WHETHER OR NOT COMPANY WAS ADVISED OF THE POSSIBILITY OF SUCH LOSS OR DAMAGES. *Some states do not allow exclusion or limitation, so this may not apply to you. This warranty gives you specific legal rights, and you may have other rights which vary from state to state.*

EXCLUSIONS TO THE WARRANTY

The Limited Warranty excludes, and Bestop is not liable in any way for any warranty claims, damages, or defects related to:

- Misuse, abuse, accidents, vandalism, negligence, fire, or improper installation or modification, or improper or inadequate maintenance;
- Failure to comply with any Product documentation, Bestop instructions, or applicable law or regulations; use in extreme conditions
- Force Majeure including but not limited to, earthquake, hurricane, tornado, flooding, or other disasters natural or man-made, civil unrest, strikes, declared or undeclared war, or lack of performance by, or discontinued product of, supply chain partners whose products, software, operations or management is beyond the control of Bestop;
- Damage resulting in breakage (including without limitation, spontaneous breakage, accidental breakage or breakage by any other means) of a Product or any component part;
- Damage to vinyl windows due to misuse, or cracking due to varying weather conditions.

YOUR SOLE REMEDY

During the applicable warranty period, Bestop shall, at its option, either repair or replace any Product that it confirms, in its discretion, is non-compliant with the warranties herein. Bestop will not pay for labor charges associated with installation or removal of the Product. Should a specific Product be discontinued, Bestop may, at its option, replace the discontinued Product with a current product or like product. If Bestop opts to repair or replace your Product as set forth herein, Bestop shall use reasonable efforts to match any patch or replacement to the color and texture of your existing Product. There is no guarantee however, that Bestop will be able to match the color or texture. If Bestop is not able to match the color or texture, it may provide you with a black or neutral colored patch replacement in its discretion.

Please retain your proof of purchase. Original proof of purchase for the Product must accompany any warranty claim. If you have a warranty claim, first you must email Bestop Customer Service at csbestop@bestop.com for instructions. All claims must be emailed to csbestop@bestop.com within 30 days of discovery of a defective Product, but in no event later than thirty days after the end of the applicable Warranty Period (the "Warranty Notice Period"). Warranty claims made after the Warranty Notice Period are null and void and Bestop shall have no responsibility with respect to such claims.

THIS SECTION SETS FORTH BESTOP'S SOLE OBLIGATION & YOUR SOLE REMEDY WITH RESPECT TO ANY DEFECTS OR OTHER PRODUCT ISSUE. ANY PRODUCTS REPLACED UNDER TERMS OF THIS WARRANTY WILL BE COVERED UNDER TERMS & BALANCE OF THE DURATION OF THE ORIGINAL LIMITED WARRANTY FOR SUCH PRODUCT.

COVERED PRODUCTS AND WARRANTY PERIODS: The warranty time periods are as follows for Products manufactured by Bestop:

BESTOP® LIMITED LIFETIME WARRANTY

Trektop® Pro Twill Fabric Top	Sunrider® for Hardtop Twill Fabric Top
Trektop® NX Glide Twill Fabric Top	Replace-a-Top™ Twill Fabric Top
Trektop® NX Twill Fabric Top	Supertop® NX Twill Fabric Top
EZFold™ Soft Tonneaus	Floor & Cargo Liners
ZipRail™ Soft Tonneaus	Pet Barriers
EZRoll™ Soft Tonneaus	

BESTOP® 5-YEAR LIMITED WARRANTY

Trektop® NX Glide™ Top (non-Twill)	Sunrider® for Hardtop (non-Twill)
Replace-a-Top™ Top (non-Twill)	Trektop® NX Top (non-Twill)
Sailcloth Replace-a-Top™	Supertop® NX Top (non-Twill)
Tigertop™ and Halftop™	Supertop® Classic Soft Top
Sunrider® Complete Soft Top	Supertop® for Truck
EZ Fold Hard Tonneau	

BESTOP® 3-YEAR/100K MILES LIMITED WARRANTY

Powerboard® & Powerboard® NX
Trekstep®, Side Mount
Trekstep®, Rear Mount

BESTOP® 3-YEAR LIMITED WARRANTY

Pavement Ends Sprint Top

BESTOP® 2-YEAR LIMITED WARRANTY

Trektop® Classic Soft Top
RoughRider™ Soft Storage

BESTOP® 1-YEAR LIMITED WARRANTY

All other Bestop® & Pavement Ends™ products not specified above.